

ISOLATION SWITCH AND AUDIO VISUAL
HIGH LEVEL ALARM WITH MUTE FUNCTION.
REMOTE MOUNTED FUNCTIONS AVAILABLE

INLET FROM HOUSE.
100mm uPVC DWV INLET
VENTING VIA TERMINAL VENT
ON SEWER DRAINS.
CHOICE OF INLET HEIGHTS

GRINDER PUMP -
RECOMENDED OPTION FOR
HANDLING SANITARY WASTE

INTEGRAL HAUNCHED
BASE.
60Mpa HIGH STRENGTH
DURABILITY ENHANCED
CONCRETE
ANTI-FLOTATION
FLANGES AS
STANDARD

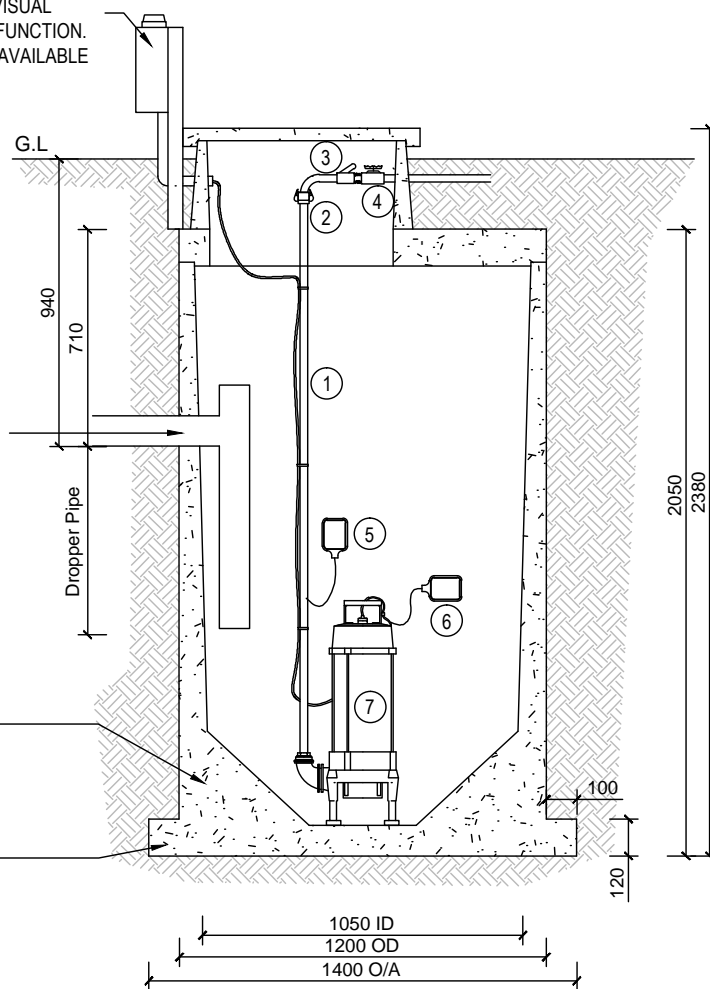

1500L HAUNCHED BASE PUMP CHAMBER
SECTIONAL VIEW

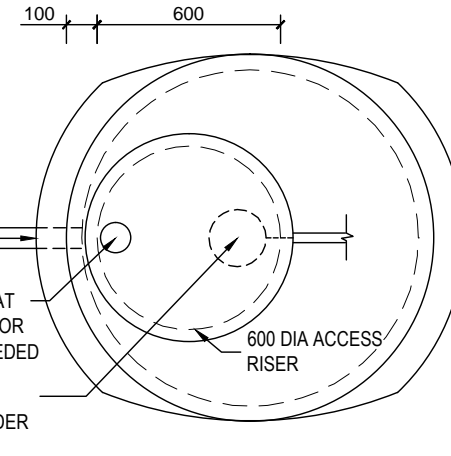

1500L HAUNCHED BASE PUMP CHAMBER
PLAN VIEW

- ① FLEXIBLE PIPE
- ② NON-CORROSIVE CAMLOCK FITTING 32mm
- ③ SEWAGE BALL CHECK VALVE 32mm
- ④ ISOLATION BALL VALVE 32mm
- ⑤ HIGH LEVEL ALARM FLOAT
- ⑥ PUMP CONTROL FLOAT
- ⑦ DAVEY D150GA PUMP *Note; Other Pump Options Available*

WEIGHT OF CHAMBER **1600Kg**
WEIGHTS OF LIDS & RISER **330Kg**

*LARGER CAPACITY PUMP CHAMBERS ARE AVAILABLE - TO GIVE A LARGER EMERGENCY RESERVE.



23 King Edward Street
Motueka 7120 NZ
Phone (03) 528 1018
Fax (03) 528 9362
Email: info@alphaprecasts.co.nz

ALPHA PUMP STATION - 1500L
SINGLE PUMP
PS1500

ENG: JU
DRN: MRH
SCALE: NTS
DATE: 09-08-2010

JOB NUMBER

PS1500 - A2

REVISION

Aug 2010